

High Density Polyethylene (HDPE) Electrofusion Fittings

HDPE Electrofusion Elbows (45° and 90°)



HDPE Electrofusion 45 Degree and 90 Degree Elbows are available to meet your needs in compliance with ASTM D2513, F1055, F2897, and where applicable, AWWA C906 product standards.

Electrofusion Fittings are manufactured from a PE 4710/PE100 resin as listed in PPI-TR4.

HDPE Electrofusion Fitting Material Physical Properties		
Property	Standard	Typical Value†
Material Designation	ASTM F412	PE4710
Cell Classification	ASTM D3350	445574C (black)
Density [4]	ASTM D4883	0.959 g/cc (black)
Flow Rate	ASTM D1238 (HLMI, Condition 190/21.6)	8.0 g/10 min
Flexural Modulus [5]	ASTM D790	150,000 psi
Tensile Strength [5]	ASTM D638 Type IV	3625 psi
SCG (PENT) [7]	ASTM F1473	10,000 hours
HDB at 73°F (23°C) [4]	ASTM D2837	1600 psi
Color; UV stabilizer [C]	ASTM D3350	Black
Pressure Class (Gas)	49 CFR 192	125 psi
Pressure Class (Water)	AWWA C906	160 psi
Ambient Fusion Temperature	Manufacturer Specification	14°F-113°F

†This is not a product specification and does not guarantee or establish specific minimum or maximum values or manufacturing tolerance for material or piping products to be supplied. Values obtained from tests of specimens taken from piping product may vary from these typical values.

HDPE Electrofusion Elbows (45° and 90°)



**45 Degree Elbow
1" to 2" IPS**

**45 Degree Elbow
3" & 4" IPS**

**90 Degree Elbow
1" to 2" IPS**

**90 Degree Elbow
3" & 4" IPS**

45 Degree Elbows				
Electrofusion Elbow Size	Weight, lbs	Box Quantity	Part Number	Manufacturer Reference
1" IPS	0.18	10	1120967	5906B003010
1-1/4" IPS	0.31	10	1120968	5906B003013
1-1/2" IPS	0.49	10	1120969	5906B003015
2" IPS	0.73	4	1120795	5906B003020
3" IPS	1.67	4	1120970	5906B003030
4" IPS	2.80	4	1120796	5906B003040

The pin size of the electrofusion fittings is 4.0mm.

90 Degree Elbows				
Electrofusion Elbow Size	Weight, lbs	Box Quantity	Part Number	Manufacturer Reference
1" IPS	0.18	10	1120963	5905B003010
1-1/4" IPS	0.31	10	1120964	5905B003013
1-1/2" IPS	0.49	10	1120965	5905B003015
2" IPS	0.73	4	1120793	5905B003020
3" IPS	1.93	4	1120966	5905B003030
4" IPS	3.35	4	1120794	5905B003040

The pin size of the electrofusion fittings is 4.0mm.

HDPE Electrofusion Elbows (45° and 90°)

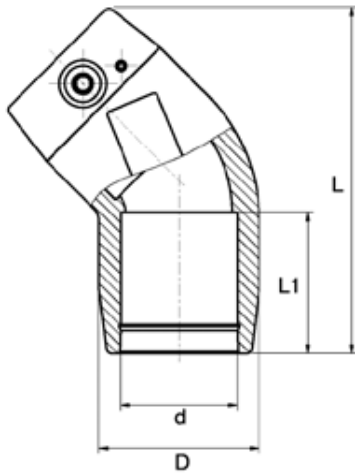

45 Degree Elbow
1" to 2" IPS

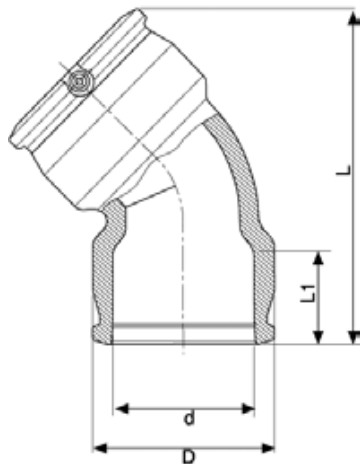

45 Degree Elbow
3" & 4" IPS

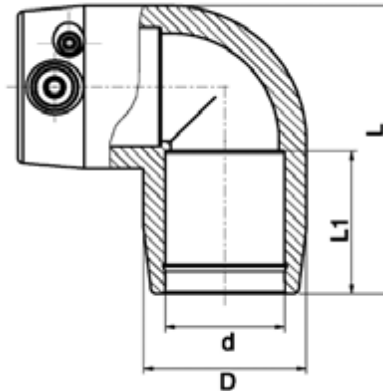

90 Degree Elbow
1" to 2" IPS

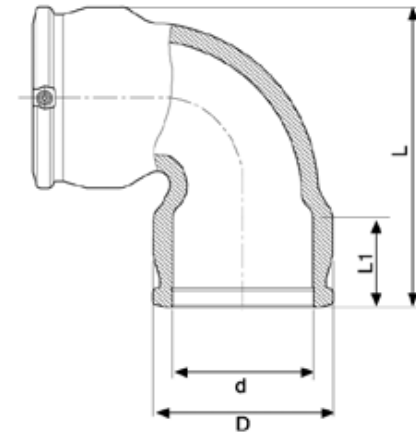

90 Degree Elbow
3" & 4" IPS

45 Degree Elbows								
Electrofusion Elbow Size	Dimensions d, inch	Dimensions D, inch	Dimensions L, inch	Dimensions L1, inch	Ω @ 20°C, ohms	Fuse Time, sec	Fuse Volts	Cool Time, min
1" IPS	1.36	1.75	3.74	1.54	2.000	30	40	5
1-1/4" IPS	1.72	2.19	4.25	1.71	2.060	60	40	5
1-1/2" IPS	1.95	2.67	4.88	1.91	2.500	120	40	10
2" IPS	2.44	3.23	5.87	2.26	1.310	80	40	5
3" IPS	3.58	4.42	9.00	2.80	0.723	100	40	10
4" IPS	4.59	5.61	10.70	3.19	0.594	140	40	10

90 Degree Elbows								
Electrofusion Elbow Size	Dimensions d, inch	Dimensions D, inch	Dimensions L, inch	Dimensions L1, inch	Ω @ 20°C, ohms	Fuse Time, sec	Fuse Volts	Cool Time, min
1" IPS	1.35	1.75	3.09	1.54	1.920	30	40	5
1-1/4" IPS	1.71	2.19	3.67	1.71	2.050	70	40	5
1-1/2" IPS	1.96	2.67	4.31	1.91	2.490	120	40	10
2" IPS	2.44	3.23	5.20	2.26	1.334	80	40	5
3" IPS	3.58	4.42	7.95	2.80	0.723	100	40	10
4" IPS	4.59	5.61	9.35	2.69	0.594	140	40	10

Before using this product, the user is advised and cautioned to make its own determination and assessment of the safety and suitability of the product for the specific use in question and is further advised against relying on the information contained herein as it may relate to any specific use or application. It is the ultimate responsibility of the user to ensure that the product is suited and the information is applicable to the user's specific application. Chevron Phillips Chemical Company LP does not make, and expressly disclaims, all warranties, including warranties of merchantability or fitness for a particular purpose, regardless of whether oral or written, express or implied, or allegedly arising from any usage of any trade or from any course of dealing in connection with the use of the information contained herein or the product itself. The user expressly assumes all risk and liability, whether based in contract, tort or otherwise, in connection with the use of the information contained herein or the product itself. Further, information contained herein is given without reference to any intellectual property issues, as well as federal, state or local laws which may be encountered in the use thereof. Such questions should be investigated by the user.