

**Fusion Parameters for
Gas Tapping Tees
Flat Gasket
Butt & Socket Outlet
Standard/Extended Chimney
Rectangular Base**

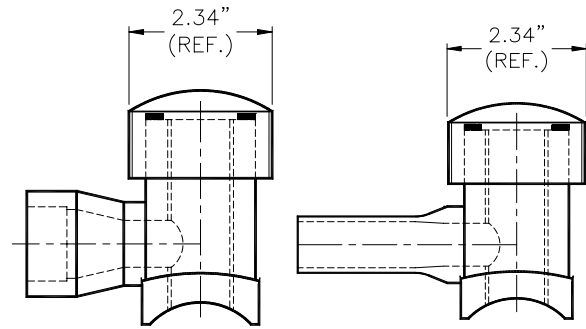

<u>Main Size</u>	<u>ALL Outlets</u>	<u>Approximate Area (in²)</u>	<u>Bead Up Force (lb)</u>	<u>Joining Force (lb)</u>
1 1/4\"/>				

WARNING - Gas pipe should be fused only by qualified persons, and only in compliance with qualified fusion procedures from the gas utility (gas pipeline owner or operator).

Use the information on this publication only with the complete, detailed fusion procedures published in Performance Pipe Bulletin PP-750. If you have questions about saddle fusion, review Performance Pipe Bulletin PP-750 before making saddle fusion joints. If the gas utility procedure differs from Performance Pipe Bulletin PP-750, observe the gas utility's saddle fusion procedure, and do not use this publication.

DISCLAIMER: Performance Pipe has made every reasonable effort to ensure the accuracy of the technical data provided herein. This data MUST be used in conjunction with Performance Pipe Bulletin PP - 750 Heat Fusion Joining Procedures. PERFORMANCE PIPE DISCLAIMS ANY LIABILITY FOR ANY PERSONAL INJURY, DEATH OR PROPERTY DAMAGE CAUSED BY ANY MISUSE OF THE INFORMATION OR ANY DEFECTS IN THE DESIGN, INSTALLATION OR MAINTENANCE OF THE PIPING SYSTEM.

The information on this bulletin does NOT apply to DRISCOPIPE® 7000 and 8000 mains or fittings.

