

K·RESIN[®]
STYRENE-BUTADIENE COPOLYMERS
The Smart Choice[™]



TIB 202
Injection Molding

Introduction

K-Resin[®] styrene-butadiene copolymers (SBC) are a family of clear resins produced by Chevron Phillips Chemical Company LP. K-Resin[®] SBC were commercialized in the early 1970's. Since that time, they have grown steadily in the marketplace as more and more applications have been developed utilizing these polymers' unique blend of sparkling clarity and impact strength.

Applications range across the spectra of conventional processing techniques. K-Resin[®] SBC, alone or in blends with crystal polystyrene, can be extruded into sheet and thermoformed on conventional equipment at high output rates. The favorable economics of K-Resin[®] SBC along with their high productivity have made possible tough clear disposable drinking cups, lids, and other packaging applications. These materials process equally well in injection molding, providing good cycle times and design flexibility. An example of an injection molded application is the clear living hinge box. The part is filled through the narrow hinge, yet still has enough toughness to provide good hinge life. In blow molding, K-Resin[®] SBC will process on most conventional equipment, allowing the molder to run a crystal clear bottle without expensive machine modifications, special molds, different screws or dryers. K-Resin[®] SBC are blow molded in a broad range of sizes and shapes, from small pill bottles and medical drainage units to very tall display bottles. They can also be injection blow molded into extremely high impact bottles with glass-like clarity. Produced as a film, K-Resin[®] SBC make a clear, stiff, high gloss film suitable for applications such as candy twist wrap, shrink sleeves and overwrap. If extreme processing and regrinding conditions are avoided, the polymers can be reprocessed in multiple passes with minimal changes in properties and processing.



A feature that makes K-Resin[®] SBC more economically attractive than other clear plastics is their low density. K-Resin[®] SBC has a 20 – 30 percent yield advantage over non-styrenic clear resins.

All K-Resin[®] SBC grades as shipped by Chevron Phillips Chemical Company LP, meet the specifications of the United States FDA Food Packaging Regulation 21 CFR 177.1640 or the specifications of an effective United States FDA Food Contact Notification. By virtue of this FDA compliance, K-Resin[®] SBC grades may be used as a component of articles for use in contact with food. Most K-Resin[®] SBC grades meet the food contact requirements for EEC Directive 2002/72/EEC and all its amendments.

Most K-Resin[®] SBC grades have been tested and meet the requirements of a USP XXIII Class VI type polymer. Even so, Chevron Phillips Chemical does not recommend using any K-Resin[®] SBC grade in medical applications that involve permanent or temporary implantation in the human body. Detailed information on the biocompatibility and sterilization methods of K-Resin[®] SBC can be obtained in TSM 292 *Medical Applications of K-Resin[®] SBC*.

K-Resin SBC Grades

Several K-Resin[®] SBC grades (KR01, KR03, KR03NW and BK10) are available for injection molding.

K-Resin[®] SBC grade KR01 is used almost exclusively for injection molding applications and exhibits significantly higher impact resistance than crystal polystyrene. KR01 provides advantages of higher warpage resistance, stiffness and surface hardness when compared to grade KR03. K-Resin[®] SBC grade KR03 is used in injection molding applications as well as sheet extrusion applications and exhibits improved toughness and breakage resistance compared to KR01. KR03 contains a microcrystalline wax that acts as an antiblock in extrusion. While the wax provides processing benefits, it can make KR03 difficult to decorate. KR03 is available in a no-wax form, KR03NW, to facilitate printing and decorating. SKR18 can be added to all grades of K-Resin[®] SBC to improved mold release and are optically enhanced. BK10 provides higher melt flow for improved mold filling performance and decreased cycle times compared to KR03.

Equipment

Clamping Force

Actual clamp force is determined by the part design, the gating of the mold and the injection pressure required to fill the mold cavity. A good rule of thumb is 3 tons/in² (41.4 MPa) of projected cavity and runner area. Projected cavity and runner area is the maximum total surface area of the part(s) and runner system reduced to two dimensions on a plane parallel to the platens. Some situations may require only 2 tons/in² (30 MPa).

Injection Unit

K-Resin[®] SBC may be processed on most conventional injection molding machines. K-Resin[®] SBC may be processed at temperatures ranging from 350 – 480°F (177 – 249°C). However, their primary benefits of optical clarity and impact toughness may be diminished as processing temperatures are increased. Thermal degradation can be caused by high melt temperatures or by extended residence time in the molding machine or mold runner system. As the resin degrades, it becomes increasingly less clear and yellows and can darken until it forms black specks. In molded parts, thermally degraded resin appears as high haze, poor clarity, silver streaks, black specks or poor surface finish such as “splay marks”. To minimize thermal degradation, the material should be uniformly plasticized using minimal heat.

Shot Capacity

Since thermal degradation is dependent on residence time as well as melt temperature, K-Resin[®] SBC should be molded in a machine having the smallest practical shot capacity. With a 55 gram part, for example, a machine having 400 gram capacity retains a cushion of six shots in the machine. In such cases, the extended residence time can produce thermal degradation even at moderate melt temperatures. Hot runner systems increase residence time and should also be considered when selecting machine size.

Processing Conditions

K-Resin[®] SBC can be processed using a wide range of molding temperatures and pressures. When compared to many clear resins, they are less sensitive to moisture and can be molded at low temperatures and with fast cycle times.

Drying

Since they do not absorb moisture, K-Resin[®] SBC do not usually require drying. They can, however, retain enough surface moisture to require drying if stored in open containers under humid conditions. Regrind often has more surface area than virgin resin and thus can retain more surface moisture. To prevent resin degradation, the regrind flakes must be dried carefully. Drying temperatures should be kept as low as practical and the drying time as short as possible. Drying for one hour at 140°F (60°C) should be sufficient. Excessive drying times or temperatures should not be allowed. Even if the resin does not degrade, its surface might soften enough to stick to other pellets, thus interrupting resin feed to the injection unit.

Melt Temperature

The single most important processing variable of K-Resin[®] SBC is melt temperature. As melt temperature increases up to 480°F (249°C), the flow of the material increases (Figure 1). Above 480°F (249°C) material flow becomes erratic. As noted above, excessive melt temperature or extended residence time at even a moderate temperature can degrade the resin, yielding poor part appearance and performance. Therefore, melt temperature should always be kept at the minimum, usually between 380 – 450°F (193 – 232°C), necessary to permit mold filling.

It should be noted that high back pressure on the screw, in order to eliminate air bubbles and enhance mixing of the melt, can increase polymer shear enough to raise the melt temperature some 10 or 20°F (5 – 10°C) above the heater temperature settings. Typical back pressures range from 50 – 150 psi (0.3 – 1.0 MPa) hydraulic.

Injection Pressure

K-Resin[®] SBC respond to injection pressure much like other copolymers. The flow length of the resin increases as injection pressure increases (Figure 2).

Figure 1
Spiral Flow as Function of Melt Temperature

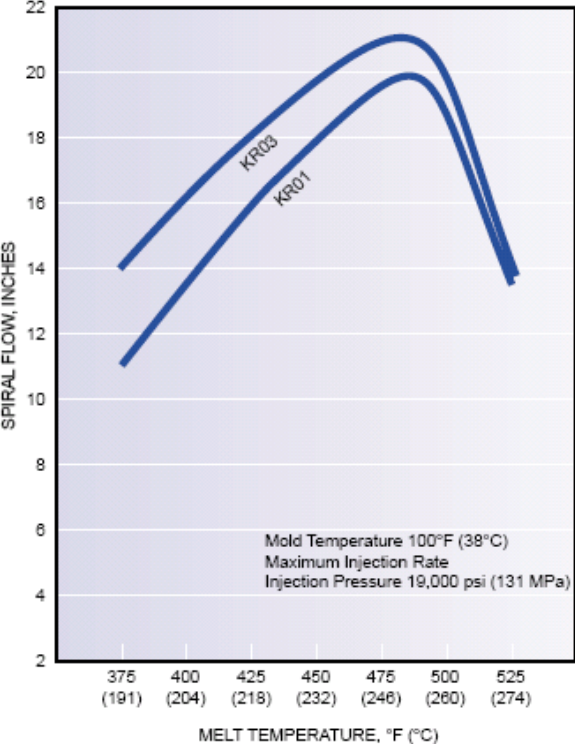
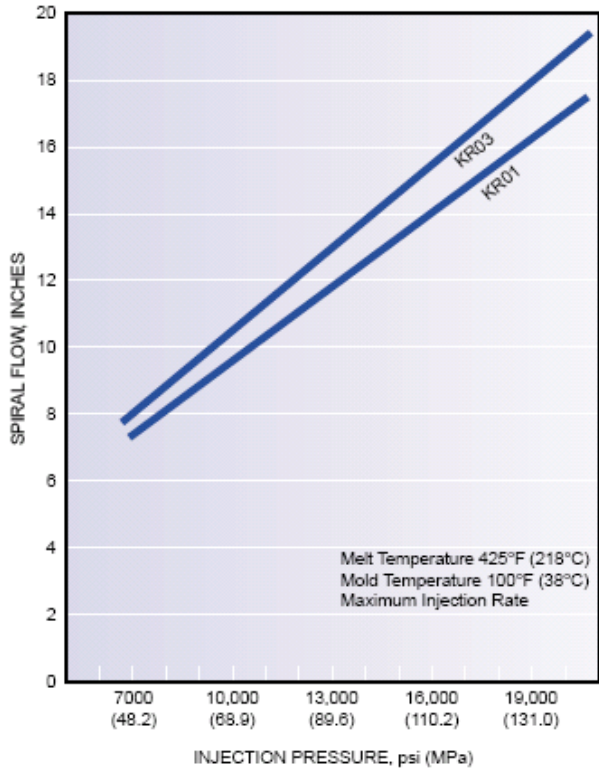

Figure 2

Spiral Flow as Function of Injection Pressure



Some parts made with K-Resin[®] SBC tend to stick in the mold when over-packed, so the injection pressures should not exceed the minimum required to fill the cavity. Of course, minimum injection pressure depends on the ease of resin flow into the cavity.

Higher injection pressures will prove necessary to overcome flow restrictions caused by small gating, thin walls and melt flow patterns. To prevent over-packing, second stage injection pressure should also be low and maintained only for the shortest practical injection hold time.

Since under-packing can result in a part having “wavy” lines or surface ripples, a balance between under and over-packing must be achieved if quality parts are to be produced.

Injection Rate

K-Resin[®] SBC are sensitive to injection rate in that flow lines can occur when the gates are too small. When flow marks are visible, particularly when jetting

occurs, a slower injection rate can eliminate the problem. On the other hand, in certain situations, a faster injection rate can improve weld line strength. For more information, refer to the discussion of weld lines under Part and Mold Design.

Mold Temperature

A wide range of mold temperatures may be used when molding K-Resin[®] SBC. Mold temperatures below 50°F (10°C) and above 150°F (66°C) can affect the clarity of the parts made. In most parts, optimum clarity occurs when the mold is maintained between 90 and 120°F (27 – 49°C). Higher mold temperatures maximize surface gloss and reproduction of mold detail. Lower mold temperatures maximize impact resistance and reduce cycle time.

Cycle Time

The cooling time for K-Resin[®] SBC is similar to polystyrene. Since cooling requires 70 – 80 percent of the cycle time, it may be minimized by reducing mold temperature, stock temperature and part thickness as much as possible without affecting part appearance and performance. Most parts can be ejected from the mold as soon as they develop sufficient strength to withstand the force of the ejection system.

Part Sticking

Some part requirements result in molds which have very little draft and these parts are often harder to eject. Sticking problems can be alleviated using any of the following suggestions:

1. Utilize K-Resin[®] SBC concentrate SKR18 which contains a mold release and blue tint. Addition rate: 1.5 percent or less.
2. If using a grade without enhanced mold release, dry blend with zinc stearate (white lubricating powder) according to the following procedure:

Step 1: Add 0.1 percent regular mineral oil to the resin and drum tumble for 5 -10 minutes (~45 grams of mineral oil per 100 lbs of resin). This wetting agent will help the zinc stearate adhere to the pellets.

Step 2: Add 0.1 percent zinc stearate powder to the pre-treated resin and drum tumble for another 5-10 minutes (~45 grams of ZnSt per 100 lbs of mineral oil coated resin). This step will ensure a uniform coating on the K-Resin[®] SBC pellets.
3. Treat the mold surface (core or cavity) with a lubricant similar to Dicronite or Poly-Ond coating. These treatments will reduce the surface coefficient of friction to enhance mold release.

Reprocessing

When reprocessing K-Resin[®] SBC, a chopper with sharp blades, close blade tolerance and adequate ventilation should be used to avoid heat buildup. Excessive temperatures in the chopper or storage container can degrade the resin yielding increased haze, erratic flow behavior and undesirable property changes. If extreme processing and regrinding conditions are avoided, K-Resin[®] SBC should easily withstand multiple passes. More information is available in TSM 315, *Reprocessing of K-Resin[®] SB Copolymer*.

Part and Mold Design

Mold Shrinkage

K-Resin[®] SBC are amorphous rather than crystalline and thus exhibit relatively low shrinkage rates. KR03 generally has slightly more shrinkage than KR01.

The degree of shrinkage for an actual part depends on both design and processing variables. As with most resins, thick sections shrink more than thin sections. When the copolymer is highly oriented during injection, it shrinks more in the flow direction than it does in the transverse direction. Certain other mold and part design features can also affect the

ability to control shrinkage. The most important processing variable is molding temperature. The copolymer shrinks less when restrained in the mold during cooling. It can shrink more if cooled outside the mold. Therefore, shrinkage control depends on the temperature at which the part is ejected. Table 1 contains the approximate shrinkage values of various part wall thicknesses using typical molding parameters.

Part Wall Thickness	KR01	KR03
0.0156 in (0.040 cm)	0.002	0.003
0.0312 in (0.079 cm)	0.002	0.003
0.0469 in (0.119 cm)	0.003	0.004
0.0625 in (0.159 cm)	0.004	0.005
0.0938 in (0.238 cm)	0.005	0.006
0.1250 in (0.318 cm)	0.006	0.007
0.1875 in (0.476 cm)	0.007	0.008
0.2500 in (0.635 cm)	0.008	0.010

Table 2

K-Resin SBC Spiral Flow Data

Part Thickness, in (cm)				
	0.025 (0.063)	0.050 (0.127)	0.075 (0.190)	0.100 (0.254)
Grade	Average Length, in (cm)			
<i>400°F (204°C) Melt Temperature</i>				
KR01	4.5 (11.4)	11.0 (27.9)	18.0 (45.7)	25.0 (63.5)
KR03	5.0 (12.7)	13.0 (33.0)	22.5 (57.2)	31.1 (94.6)
<i>450°F (232°C) Melt Temperature</i>				
KR01	5.5 (14.0)	13.4 (34.0)	23.0 (58.4)	27.5 (69.9)
KR03	6.4 (16.3)	16.5 (41.9)	27.5 (69.9)	39.04 (99.1)

Wall Thickness

Part walls should be of sufficient thickness to allow easy fill of the mold. The spiral flow characteristics of K-Resin® SBC grades KR01 and KR03 are shown in Table 2. All processing variables are constant; only the thickness of the mold cavity varies. BK10 provides improved flow lengths, typically 10-20 percent higher than for KR01 or KR03.

Warpage

KR01 shrinks less than KR03 and also tends to warp less. If a part warps when molded with KR03, a blend of KR03 and KR01 will minimize warpage while still retaining some impact strength. The impact strength of a blend is directly related to its KR03 content (a higher KR03 content will maintain a higher impact value). To attain maximum

warpage resistance, a higher percentage of KR01 should be used.

BK10 will have slightly more warpage than KR03.

Weld Lines

A weld line is the junction line produced when the melt streams converge, usually after flowing around an obstruction or part feature that splits the melt stream. The strength of the copolymer at a weld line may be evaluated by testing specimens molded in a cavity gated at both ends. Studies indicate that properly molded weld-line specimens of K-Resin® SBC can exhibit nearly the same tensile strength as single-gated specimens having no weld line. The elongation of weld-line specimens, however, is significantly lower. Thus, a weld line may prove to be the weakest spot of a molded part, especially if subjected to flexure. Whenever possible, the part should be designed so that mold gating can eliminate weld lines altogether. When a weld line cannot be eliminated, it should be placed in an area where full strength is not critical or where it can be protected from high stresses.

In any case, the strength of a part at an unavoidable weld line can be maximized by proper mold venting (the most critical variable) and molding conditions. As melt streams converge, they can entrap air and compress it rapidly during the injection cycle. Rapidly compressed air can superheat enough to degrade the melt which reduces both the strength of the polymer and its ability to knit together as melt streams converge. Proper venting can increase the tensile strength of weld-line specimens as much as 30 to 40 percent. Thus, vents should be as large as practical without affecting the appearance of the part and properly located to maximize weld-line strength. Vacuum venting is less effective than adequate vent size but may produce somewhat more consistent weld-line strength.

Weld-line strength may also be maximized by regulating the cavity fill rate. Cavity fill rate depends independently on injection speed and injection pressure. Both may be increased for cumulative effect. However achieved, increasing cavity fill rate increases weld-line strength significantly if venting is adequate. In a poorly vented tool, increased fill rate can increase air entrapment and thus reduce weld-line strength. When melt and mold temperatures are very low for fast cycles, thin-walled parts may need fast fill rates just to fill out the cavity. The effectiveness of increased fill rates is thus limited by the minimum rate which will fill out the tool. It should be noted that increases in stock and mold temperature produce little apparent improvement of weld-line strength.



Undercuts

Compared to some thermoplastics, K-Resin[®] SBC are rather rigid with modest elongation. Thus, the parts cannot be deformed easily enough to eject around large undercuts, typically 0.006 in (0.15 mm) or larger. An undercut greater than 0.01 in (0.25 mm) will require a mold with collapsible cores or with core pulls. Where possible, part design should avoid large undercuts altogether.

Hinge Design

An integral hinge for K-Resin[®] copolymers may follow the design of either conventional polyolefins (Figure 3a) or non-polyolefins (Figure 3b). Conventional polyolefin hinge designs have been successfully used with K-Resin[®] copolymers to allow greater filling distances opposite the hinge, but these conventional designs sometimes lead to reduced hinge life and create unacceptable mechanical interference when closed more than 160 degrees from the molded position. The non-polyolefin design allows a 180 degree closure without mechanical interference, but is more difficult to fill opposite the hinge. For both hinge designs, the hinge thickness is critical. Too thick a hinge is hard to flex; too thin a hinge is simply too weak for good hinge life. The best hinge life occurs in hinges 0.01 to 0.02 in (0.25 to 0.50 mm) thick with optimum hinge life between 0.012 and 0.015 in (0.30 and 0.38 mm). It is important to prevent weld lines from falling on the hinge, so typically hinged parts are gated only on one side of the hinge.

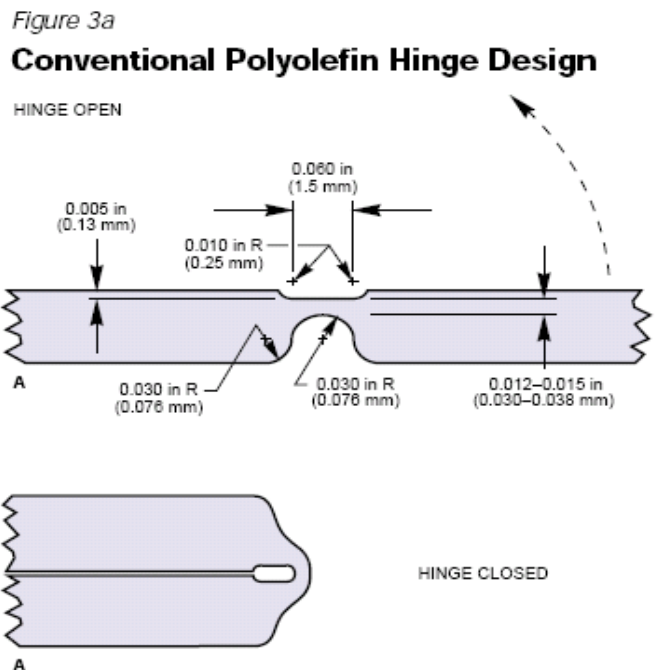
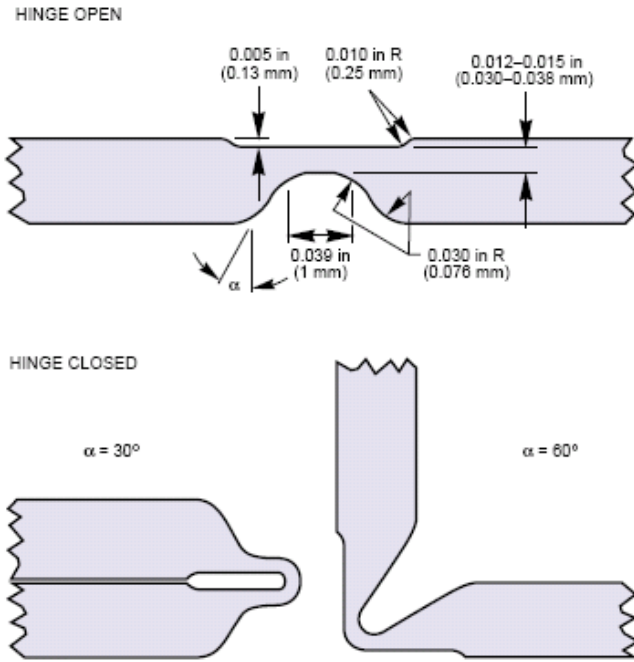

Figure 3b

Non-Polyolefin Hinge Design



successfully molded with draft angles as low as 1°.

Mold Venting

Since K-Resin[®] SBC are sensitive to thermal degradation, it is imperative that the mold be generously vented to prevent gas entrapment, subsequent overheating, which can result in burning of the resin. Fortunately, resin flow is not extremely high, so sizeable vents will not affect part appearance. The well-designed tool can incorporate vents from 1 to 3 mils (0.03 to 0.08 mm) thick completely around the cavity. As discussed above, adequate venting is particularly critical for maximum weld-line strength. If weld lines cannot be avoided, they must be generously vented to allow adequate latitude to correct weld-line problems. In most parts, vacuum venting is not more effective than adequate vent size, but it may prove helpful in attaining consistent weld-line strength in molds having unpredictable melt flow patterns or inadequate venting.

Ejection System

The outstanding mold replication of K-Resin[®] SBC yields high surface gloss but can also make parts difficult to eject. If possible, the ejection force should be distributed throughout the part. An ejector plate or stripper ring is preferred for parts with regular geometry and/or large flat surfaces such as drinkware, medical cups, boxes and other large corded parts. When part geometry precludes the use of an ejector plate, ejector pins should be as large as possible to prevent them from puncturing the part. The hotter the part, the easier it is to loosen from the core, but it is also weaker and easier to puncture. The mold may also be equipped to introduce air between the core and the part to break any vacuum which may exist or to reduce the intimacy of surface contact. This method of providing air between core and part should not,

Flexing the hinge while still hot from the mold does not substantially increase hinge life as it may for other materials. Likewise, melt temperature has little effect on hinge life until it is high enough to degrade the melt.

Grade KR01 provides the best hinge life of all K-Resin[®] SBC injection molding grades. It is possible to improve the hinge life of all K-Resin[®] SBC grades by addition of an SBS rubber.

Draft Angle

To facilitate easy ejection, all injection molds should have as much draft as the part design will allow. This general design policy is particularly true for K-Resin[®] SBC produced parts. These parts have such a smooth, glossy surface that they tend to stick in highly polished molds, especially on deep cores. For those parts, the draft angle should be at least 3°. However, in some cases, shallow parts have been

however, compromise the part clarity and surface gloss resulting from highly polished molds. Refer back to page 6 for part sticking.

Mold Cooling

To minimize warpage, K-Resin[®] SBC should be uniformly cooled. Thus, the tool should be designed to provide uniform cooling of adequate capacity to maintain mold temperature throughout the optimum range. Since the polymer at the gate area is the hottest and usually the thickest, to minimize molded-in stress, this area generally requires additional cooling. Bubblers have proven effective in many tools.

Runner System

K-Resin[®] SBC have been successfully molded in all types of injection molds: 2-plate, 3-plate, insulated runner, stack and hot runner. The preferred mold type depends largely on part geometry and number of cavities. The most important consideration for any runner system with heaters is that the flow pattern be as streamlined as possible. Since excessive residence time can cause thermal degradation of the melt yielding poor clarity and part performance, runner design must eliminate dead spots so the resin does not stagnate. For similar reasons, runner system heaters should be equipped with temperature controllers rather than rheostats and should minimize resin volume.



Gating

Molds for K-Resin[®] SBC can use all type of gates, including sprue, submarine, pin, tab, fan and multiple; however, small gates should be avoided. If the gate size is too small, it can cause polymer shear during injection and generate enough heat to degrade the polymer. For most K-Resin[®] SBC produced parts, the gate size should be approximately 75 percent of the part wall thickness when that thickness exceeds 0.050 in (1.27 mm). For thinner walled parts, the gate should be as large as practical. Except for submarine gates in very small parts, no gate should be smaller than 0.030 in (0.76 mm). Although gate sizes are not as critical in edge-gated parts such as flat items, excessively small gates can still cause overheating due to shear. Edge gates are usually tab or fan types which allow variation of width as well as thickness. To fill a cavity properly, a gate must become wider as it becomes thinner and it should be as large as the part appearance will allow.

Part appearance may also determine gate location. That is, the gate may be located so it is not readily visible. Furthermore, gate location can affect part performance significantly. The copolymer at the gate is the last and hottest melt injected into the mold. Even if the mold has extra cooling capacity at the gate, the part is often thicker, resulting in poor performance due to differential shrinkage. The reduction in strength can be minimized by processing parameters such as cooling and degree of packing. Even so, the gate should be located in an area of the part where full mechanical strength is not critical or where it can be protected from external abuse.

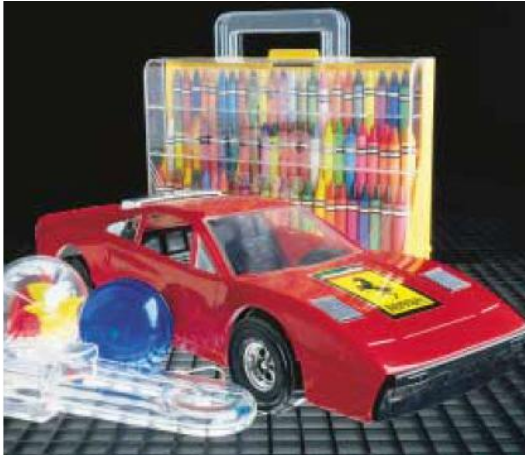

To minimize warpage, the gate or gates should be located so that the mold cavity fills as uniformly as possible. Symmetrical parts like cups and tumblers, for example, can be filled uniformly from a center gate. To control shrinkage, the processor must be able to adjust the degree of packing and thus, polymer density throughout the part. If possible, therefore, the gate should be located so that the cavity fills from the largest volume or thickness to the smallest. Otherwise, a small or thin section near the gate could freeze off enough to limit packing of a larger section farther away. Most flat parts, for example, can be filled from an edge gate more uniformly than in expanding rings from a center gate.

On the other hand, some very large parts may need to be gated at the center simply to fill the part.

Very irregular mold flow patterns can also create unnecessary weld lines or aggravate unavoidable weld lines. Converging melt streams may entrap air which can overheat when compressed rapidly, burn the polymer and yield poor part performance and appearance at the weld line. Therefore, weld lines must be well vented. The gate should be located so that the weld lines occur in locations with generous venting and where part appearance or full strength is not critical. When possible, the gate should be located so as to avoid weld lines altogether.

Equipment

Even in the best of operations, occasional problems develop. The most likely difficulties that may occur are listed below, with probable causes and solutions.

Injection Molding Troubleshooting Guide

Problems	Possible Causes	Suggested Solutions
Black specks and streams	<ol style="list-style-type: none"> 1. Resin burned by excessive temperature. 2. Resin burned by excessive residence time in the barrel. 3. Resin contamination 	<ol style="list-style-type: none"> 1. Reduce processing temperature. 2. Streamline runner system to eliminate areas of stagnant resin. Clean to streamline nozzle and non-return valves to eliminate areas where degraded resin may accumulate. 3. Eliminate resin contamination in storage. Purge molding machine.
Silver, smoke or milky streams	<ol style="list-style-type: none"> 1. Resin degraded by excessive melt temperature. 2. Resin degraded by high shear rates developed in molding machines, mold runner systems or gates. 3. Resin contamination. 	<ol style="list-style-type: none"> 1. Reduce stock temperature. 2. Decrease injection rate and pressure. Increase mold gate size. Increase nozzle orifice diameter. 3. Eliminate resin contamination in storage. Purge molding machine.
Mold plate-out	<ol style="list-style-type: none"> 1. Some grades of K-Resin[®] SBC contain an anti-blocking agent that can plate-out on the mold. 	<ol style="list-style-type: none"> 1. Lower stock temperature to 400°F (204°C) or below or select a K-Resin[®] SBC with no wax additive.
Parts sticking in mold	<ol style="list-style-type: none"> 1. No draft angle. 2. Excessive packing. 3. Shrinkage or sticking onto core. 4. Part design can not be changed. 5. Parting line on mold may be damaged. 	<ol style="list-style-type: none"> 1. Increase draft angle. 2. To reduce packing, reduce injection and packing pressure and hold time. 3. To reduce shrinkage onto core, reduce melt temperature or eject part earlier/warmer. 4. (a) Add 1.5% SKR18 to base material or add 0.1% zinc stearate. (b) Break vacuum between part and core, e.g., blow air through poppet valve. 5. Check parting line to make sure no burrs drag up plastic when mold is opened or part is ejected.
Surface ripples or wavy lines	<ol style="list-style-type: none"> 1. Insufficient packing. 	<ol style="list-style-type: none"> 1. (a) Increase injection pressure or injection hold time. Increase feed or shot size. Increase stock temperature. (b) Use higher flow K-Resin[®].
Bubbles in thick parts	<ol style="list-style-type: none"> 1. Air trapped in the resin during processing. 	<ol style="list-style-type: none"> 1. (a) Increase back pressure on injection unit. (b) Increase packing, especially injection hold time.
Shrink voids in thick parts	<ol style="list-style-type: none"> 1. Surface can freeze solid while molten center continues shrinking. Shrinkage differential can pull material apart and form voids. 	<ol style="list-style-type: none"> 1. Reduce cycle time. Parts ejected hotter mean surface and center portion can shrink at same rate. Increase mold temperature and decrease stock temperature to reduce temperature differential in part.

FOR FURTHER INFORMATION OR
TECHNICAL ASSISTANCE, CONTACT:

THE AMERICAS

(includes North, Central, South Americas and the Carribean Area)

CHEVRON PHILLIPS CHEMICAL COMPANY LP
10001 SIX PINES DRIVE
THE WOODLANDS, TX 77380
TEL: 800-356-2592
FAX: 832-813-4920

EUROPE/AFRICA/MIDDLE EAST

CHEVRON PHILLIPS CHEMICALS INTERNATIONAL N.V.
BRUSSELSESTEENWEG 355
B-3090 OVERIJSE, BELGIUM
TEL: 32-2-689-1211
FAX: 32-2-689-1472

ASIA

CHEVRON PHILLIPS CHEMICALS ASIA PTE. LTD.
5 TEMASEK BOULEVARD, #05-01
SUNTEC CITY TOWER
SINGAPORE 038985
TEL: 65-6517-3100
FAX: 65-6517-3277

www.cpchem.com
www.k-resin.com



This product was manufactured in a plant whose quality management system is certified or registered as conforming to the requirements defined in the ISO 9001 Standard.

Before using this product, the user is advised and cautioned to make its own determination and assessment of the safety and suitability of the product for the specific use in question and is further advised against relying on the information contained herein as it may relate to any specific use or application. It is the ultimate responsibility of the user to ensure that the product is suited and the information is applicable to the user's specific application. Chevron Phillips Chemical Company LP does not make, and expressly disclaims, all warranties, including warranties of merchantability or fitness for a particular purpose, regardless of whether oral or written, express or implied, or allegedly arising from any usage of any trade or from any course of dealing in connection with the use of the information contained herein or the product itself. The user expressly assumes all risk and liability, whether based in contract, tort or otherwise, in connection with the use of the information contained herein or the product itself. Further, information contained herein is given without reference to any intellectual property issues, as well as federal, state or local laws which may be encountered in the use thereof. Such questions should be investigated by the user.